

# PIUSI K700 METER MECHANICAL 40MM FF 20- 220LPM LITRE DISPLAY F00540000

F00540000

## FLUID COMPATIBILITY

Diesel

Mechanical flow meter with 4-digit totaliser, rated 20-220 L/min for diesel. DN40 (1 1/2 BSP female) inlet/outlet, aluminium body, non-resettable batch display.



## FEATURES

- Made in Italy by Piusi
- Elliptical Gears for the high precision measurement
- Supplied with inlet strainer
- Designed to be calibrated, refer Manual for instruction
- Suitable for use in gravity dispensing and pumped dispensing applications

## TECHNICAL SPECIFICATIONS

Flow Rate	40-220 l/min	Precision	± 1.5%
Repeatability	0.3%	Packaging	240mm L x 240mm W x 275mm H
Weight	5.8kg	Body	Aluminium
Meter Dimensions	181mm L x 151mm W x 238mm H	Gears	Technopolymer
Operating Pressure	10 Bar (145 PSI)		

## USE CASE & APPLICATION

- Depot diesel dispensing
- Fleet refuelling stations
- High-flow mobile bowsers
- Farm fuel management
- Industrial diesel transfer



FUEL MANAGEMENT SYSTEMS



DISPENSERS



KITS



PUMPS



METERS



NOZZLES

# K700

## FEATURES

- HEAVY DUTY CONDITIONS
- STURDY STRUCTURE
- BURSTING PRESSURE 30 BAR
- NO BATTERY NEEDED
- EASY TO INSTALL
- 2 FLOW DIRECTION

Medium-high flow rates require specific measuring equipment able to adapt precisely to the flow: It is the case of the oval gear mechanical flow meter PIUSI K700: a sturdy, reliable and easy to install equipment suitable for the most demanding environments. The meter displays 4-digit piece of equipment partial total that can show up to a maximum of 9999 liters.

### PERFORMANCE

**40-200**

L/MIN  
FLOW RATE

**10 BAR**

MAX OPERATING  
PRESSURE

**± 1,5%**

ACCURACY

**0,3%**

REPEATABILITY



K700



### PACKAGING

CODE	WEIGHT		PACKAGING			N. BOXES / EUROPALLET	
	KG	LBS	MM	INCH	PCS/BOX	✈	🚚
FO0540000	5,8	12,8	240X240X275	-	1	48	72
FO0540020	5,8	12,8	240X240X275	-	1	48	72
FO0540030	5,8	12,8	240X240X275	-	1	48	72
FO0540040	5,8	12,8	240X240X275	-	1	48	72



FILTRATION



TANK MONITORING



HOSE REEL



ACCESSORIES



MERCHANDISE



ANY BIODIESEL



AIR



ANTIFREEZE



AdBlue®



HVO/XTL



DIESEL



FOOD



GASOLINE



GREASE



KEROSENE



OIL



WATER



WINDSCREEN

## CHART

### K700

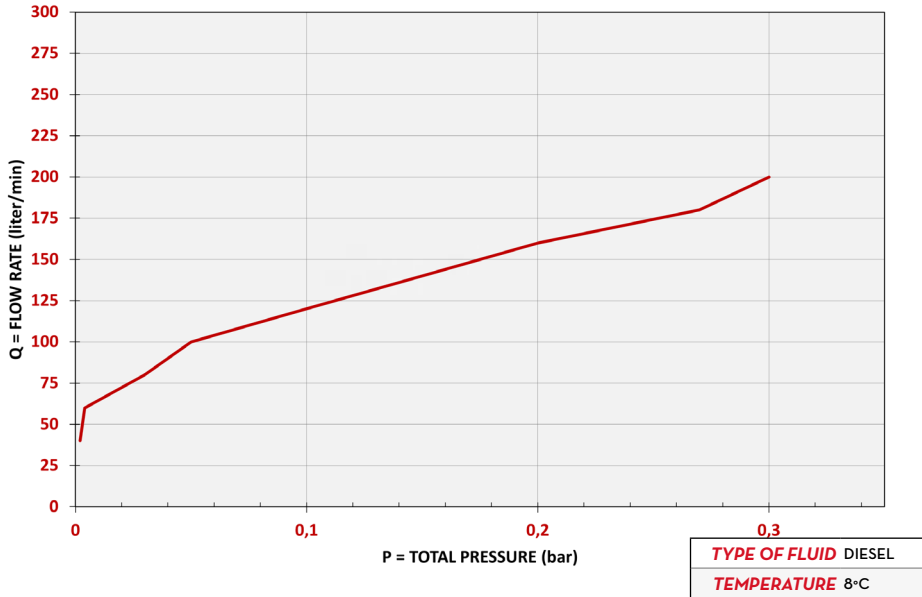

TYPE OF FLUID DIESEL  
TEMPERATURE 8°C

## DIMENSIONS

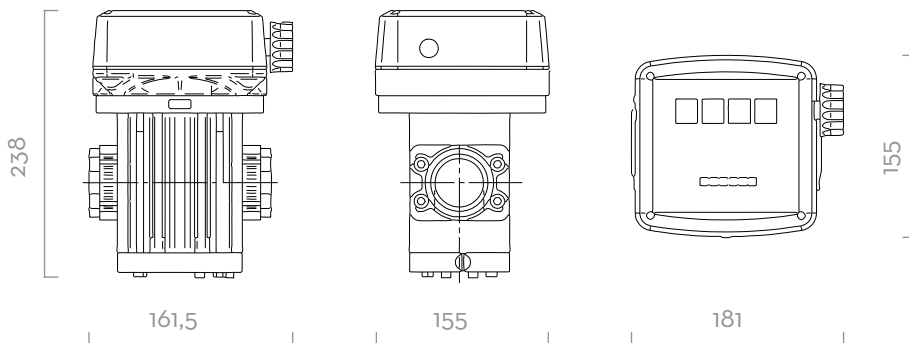

Dimensions expressed in millimeters

## IN THE BOX

- K700 METER
- INSTRUCTION MANUAL

## DETAILS



4-DIGITS



OVAL GEARS



4 FLOW DIRECTIONS

## MATERIALS

- BODY: ALUMINIUM
- GEARS: TECHNOPOLYMER

## TECHNICAL DATA

CODE	DESCRIPTION	FLUIDS TYPE	FLOW DIRECTION	FLOW RATE		PRESSURE		INLET FILTER	INLET / OUTLET
				L/MIN	GPM	BAR	PSI		
FO0540000	K700 VER. A	D	←	40 - 200	5 - 53	10	142	YES	1" 1/2 BSP
FO0540020	K700 VER. B	D	↑	40 - 200	5 - 32	10	142	YES	1" 1/2 BSP
FO0540030	K700 VER. C	D	↓	40 - 200	5 - 53	10	142	YES	1" 1/2 BSP
FO0540040	K700 VER. D	D	→	40 - 200	5 - 32	10	142	YES	1" 1/2 BSP